

Student Design Competition Submission Form For Technical Committees

1. The title of your Student Design Competition:

Four-channel Switchable/Reconfigurable Filter Bank

2. Brief description of competition and rules.

The switchable or reconfigurable filter bank is required in RF front end to accommodate the changes in spectrum and reconfiguration as an adaptive filtering. This type of filters is commonly used in military and high-end commercial applications needing signal integrity, including electronic warfare (EW) and electronic intelligence (ELINT) system. The objective of this competition is to demonstrate the effective channel filter design in conjunction with switching circuits to provide the required filter performance. The proposed design for this student competition is a switchable filter bank for the bandwidth of 1.0 - 3.0 GHz with four-channel bandpass filter performance. Each channel has the 500 MHz passband bandwidth. The filter has RF connectorized finishing with control signal connectors.

Design Specifications and Rules:

The switchable filter bank could be composed of any type of lumped, planar, or cavity resonators for a channel filter design along with RF or Microwave switch circuits. The RF switches must be controlled electronically to make each channel state. RF switch could be any type of circuitry using solid state switches or RF relays. The filter bank must have female SMA connectors on the edges of the filter for the measurement. The filter will be evaluated based on the performance measured between the SMA connector interface reference planes. A network analyzer and power voltage sources (0-20 Volts, 0-100 mA) will be available for measurements and filter reconfiguration. The filter bank size would be as small as possible. The size factor will be considered for the scoring. The total score will be calculated based on the following four filter specifications.

Channel Filter specifications:

- Channel 1 :
 - Passband :1- 1.5 GHz, Bandwidth 500 MHz
 - Insertion loss: as low as possible
 - Stopband : > 20 dB for DC - 0.75 GHz and 1.75 – 3 GHz

- Channel 2 :
 - Passband :1.5 – 2.0 GHz, Bandwidth 500 MHz
 - Insertion loss: as low as possible
 - Stopband : > 20 dB for DC - 1.25 GHz and 2.25 – 3 GHz

- Channel 3 :
 - Passband :2.0 – 2.5 GHz, Bandwidth 500 MHz
 - Insertion loss: as low as possible
 - Stopband : > 20 dB for DC - 1.75 GHz and 2.75 – 4 GHz

- Channel 4 :
 - Passband :2.5 – 3.0 GHz, Bandwidth 500 MHz
 - Insertion loss: as low as possible
 - Stopband : > 20 dB for DC - 2.25 GHz and 3.25 – 4 GHz

The Measurement Process:

The final phase of this competition will be conducted during the IMS 2019 Symposium through measurements at the conference exhibition for each competing submission. A member of each student team must be in attendance and will be required to switch their filter into the four filter states for measurement. A score will be calculated based on filter performance for each measured state. The total score will be the cumulative score for four states.

Scoring:

The goal of this competition is to design a low loss and high rejection of switchable or reconfigurable filters that meet the required specifications.

A score will be calculated based on filter performance measured state. Each channel filter will be measured in four states of bandpass filter at channel band according to the given specifications. The following formulae will be used for the scoring. The accumulated each filter state points will be added up and subtracted by size factor for the final score.

The entries with the highest number of points will win the prizes.

Final score = (Ch.1 filter response + Ch.2 filter response + Ch.3 filter response + Ch.4 filter response) - size

Where

Ch.1 filter response = $(m_4+m_5) - 2 * (m_1 + m_2 + m_3)$

Ch.2 filter response = $(m_4+m_5) - 2 * (m_1 + m_2 + m_3)$

Ch.3 filter response = $(m_4+m_5) - 2 * (m_1 + m_2 + m_3)$

Ch.4 filter response = $(m_4+m_5) - 2 * (m_1 + m_2 + m_3)$

Where m_1 , m_2 , and m_3 are the insertion loss ($s_{21}(\text{dB})$) in the passband, and m_4 , m_5 are insertion loss ($s_{21}(\text{dB})$) in the stopband of each channel filter at the maker frequencies, respectively.

Example:

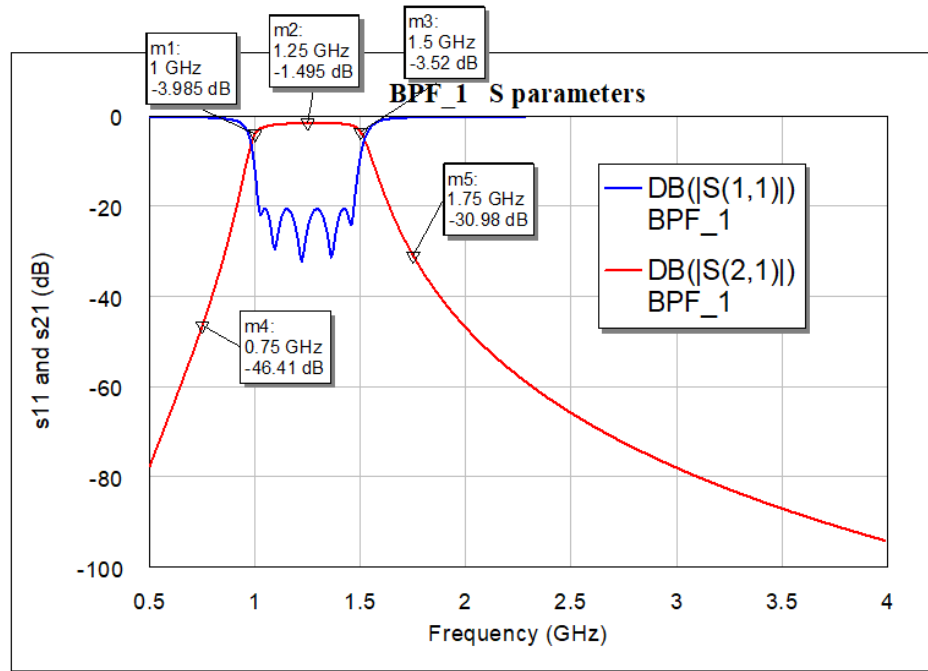

Fig.1 Channel 1 estimated response: s21 (dB) reading will be round to the first decimal point at each marker frequencies.

$$\text{Ch.1} = [m4(46.4) - m5(31.0)] - 2 * [m1(3.9) + m2(1.5) + m3(3.5)] = 59.6$$

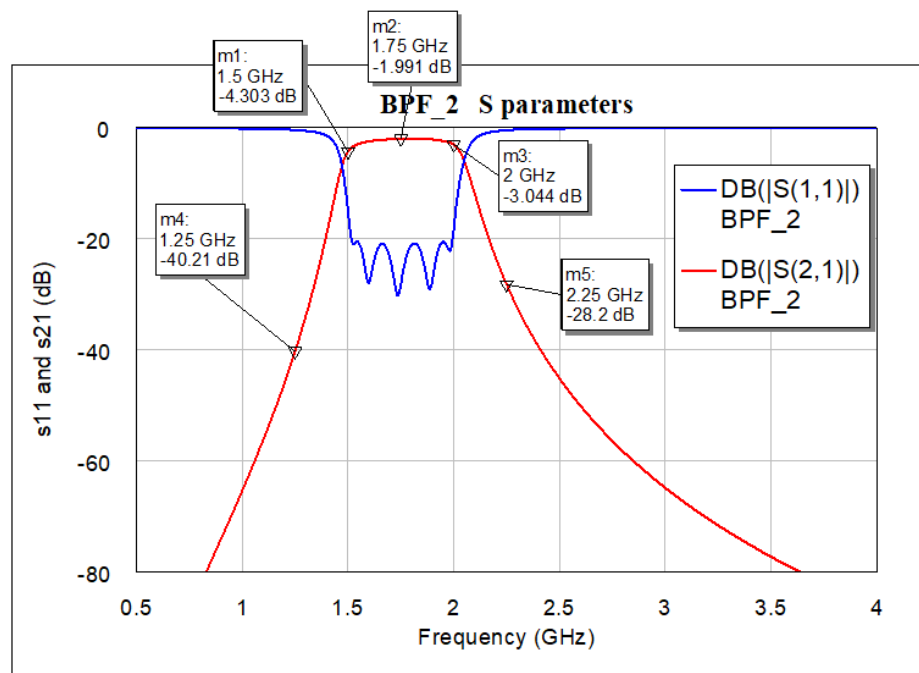

Fig.2 Channel 2 estimated response, s21 (dB) reading will be round to the first decimal point at each marker frequencies.

$$\text{Ch.2} = [m4(40.2) - m5(28.2)] - 2 * [m1(4.3) + m2(2.0) + m3(3.0)] = 49.8$$

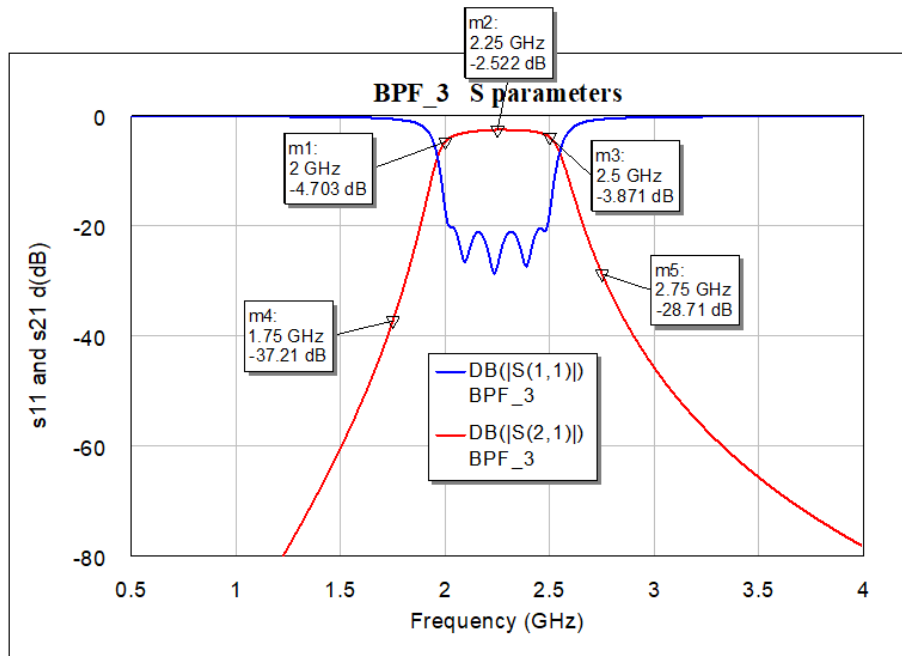

Fig.3 Channel 3 estimated response, s21 (dB) reading will be round to the first decimal point at each marker frequencies.

$$\text{Ch.3} = [m4(37.2) - m5(28.7)] - 2 * [m1(4.7) + m2(2.5) + m3(3.9)] = 43.7$$

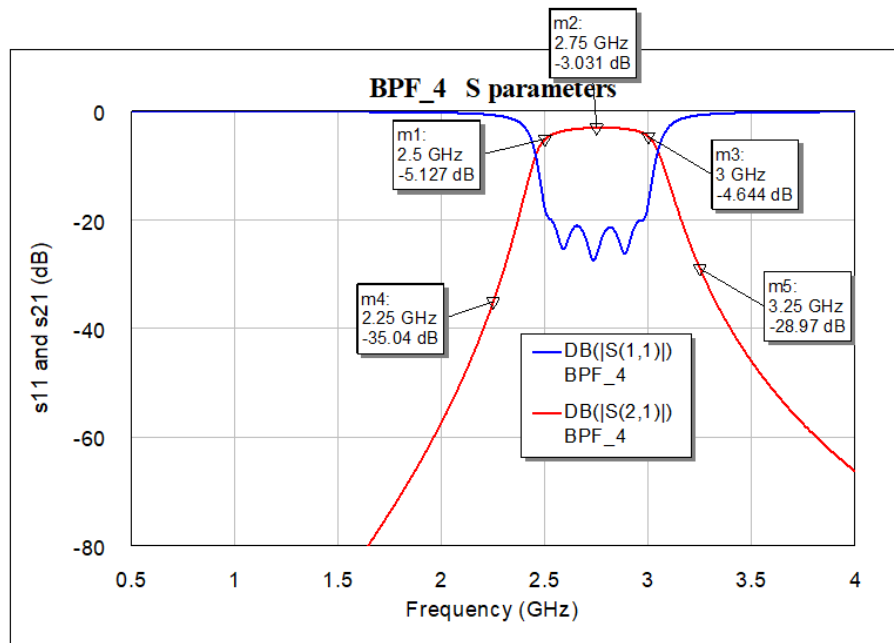
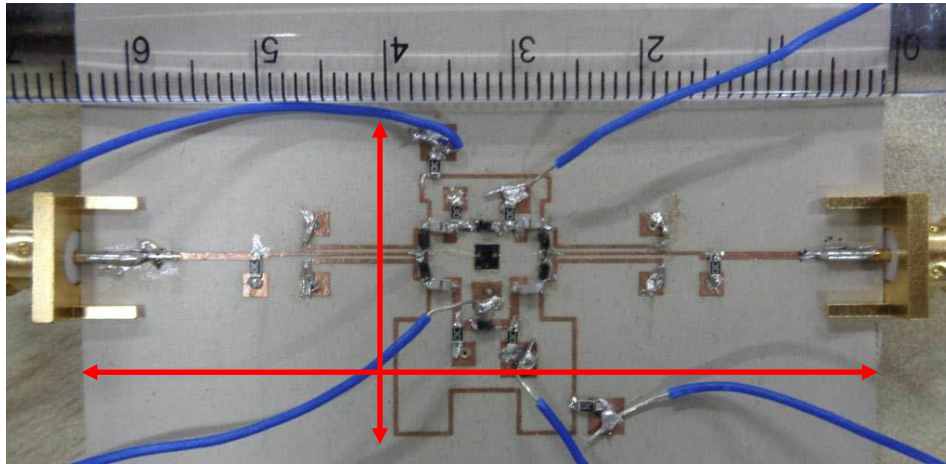

Fig.4 Channel 4 estimated response, s21 (dB) reading will be round to the first decimal point at each marker frequencies.

$$\text{Ch.4} = [m4(35.0) - m5(29.0)] - 2 * [m1(5.1) + m2(3.0) + m3(4.6)] = 38.6$$

Size: The following design will be used to demonstrate how size will be measured, assuming that size is decided to be an area at the competition:



This filter will be measured to be 6.3 cm wide and (approximately) 2.5 cm long, for a total size of 15.75 cm². Red arrows have been added to show the measurements.

Please note that showing this filter to demonstrate size measurement is not a suggestion or relevant way to implement your filter for the competition. It is merely a convenient image for demonstrating size measurement. A packaged finishing would be preferable.

- Note: If there are three-dimensional filter entries, the volume of the filters will be measured. If all of the entries are planar filters, size will be measured as the area of the circuit, and the height of the surface-mount components will be neglected. Please note that in this competition the volume or area will be defined as the product of the longest two or three dimensions (rounded to the nearest mm) and include the area required by the connector launches. This definition will be adopted to reduce measurement time. The score total from the remaining measurements will be divided by half of the size of the filter in cm² or cm³ to compute the composite score for the filter.

The final score will be calculated by adding up each channel filter score for the total score and subtracting by size factor.

Final score = (ch.1 + ch.2 + ch.3 + ch.4) - size = (59.6 + 49.8 + 43.7 + 38.6) – 15.75 = 175.95

The entries with the highest number of points will win the prizes.

3. Your Technical Committee number and name:

- *MTT-8 (Filters and Passive Components)*

4. Contact names, email addresses, and phone numbers of all competitions organizers:

- Sanhoon Shin, s.shin@ieee.org, 202-767-3526
- Eric Naglich, eric.j.naglich@ieee.org 571-218-4310

5. Historical participation numbers (if this competition has been hosted in previous years)

- Typically there are 7-12 teams

6. Projected number of participants. If this is a new competition or has historically had low participation (< 4 teams), please also include a list of at least 6 universities or professors you will contact to invite their students to participate.

- 9 teams

7. Are you willing to take responsibility for obtaining the equipment needed for your competition from Keysight, Rohde & Schwarz, local universities, etc.? Note: this is a requirement for the 2019 Student Design Competitions.

- a network analyzer, four DC power supplies, cables, and adapters.



Please send this form to: **mark.hickle@gmail.com**

Submit **no later than September 1, 2018**

