

Switched Acoustic Filter Module

TC6 – RF MEMS and Microwave Acoustics Committee

Introduction:

Microwave acoustic filters (SAW, BAW) are the prevailing filter technology in RF frontends of mobile handsets, due to their compactness, low price, and high selectivity. To keep up with the demand for multiplexers, engineers are usually required to combine (off-the-shelf) SAW/BAW components with RF switches for a multi-band multiplex filter. In this competition, our sponsors Qorvo and Menlo Microsystems will provide the contestants with appropriate BAW and RF-MEMS components. The students are required to design and assemble a band 1/2/3/7 switched multiplexer module. The measurements will be taken at IMS 2024 with support by Keysight Technologies.

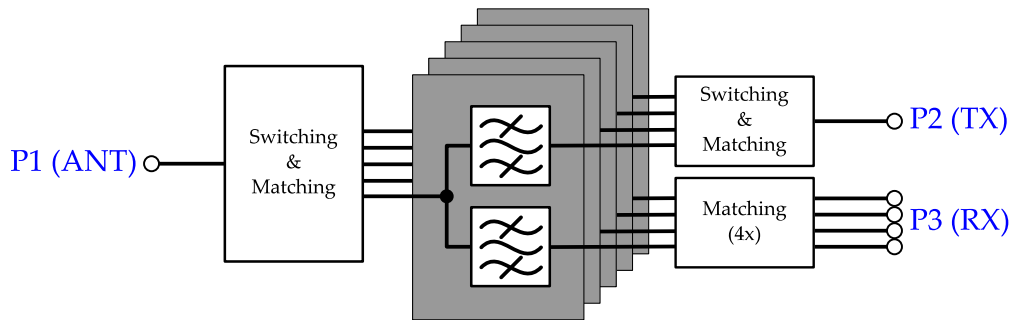

Figure 1. Schematic of multiplexer module to be designed

For simplification, only antenna and TX ports are switched. The RX bands are fed separately. Thus, the final circuit will have 6 ports (1× Tx; 1× Ant; 4× Rx).

Design Specification and Rules:

- The circuit must incorporate RF passive components only. Use of amplifiers in the RF path is not allowed.
- The design must incorporate the QM23002 and QM26001 from Qorvo and MM5120 from Menlo Microsystems. Designs that deliberately spoil the isolation and stop-band rejection of the BAW components (e.g., bypass them or not use them at all), or use other high Q filter technology other than provided, are subject to disqualification.
- Components and their s-parameter data as well as additional information will be sent to the participants after registration. Please send an email to mtt2sdc@listserv.ieee.org.
- The circuit must be designed using commercially available components only.

- The circuit board must have a rectangular outline. Only the actual PCB size is measured (protruding RF and DC connectors are excluded). For handling simplification, boards shall have a size of $5 \times 5 \text{ cm}^2$. The module should be planar.
- The mechanical design should allow for internal inspection of all relevant components and circuit elements.
- Female 50Ω SMA end-launch connectors must be used. The connectors must be placed at the outer dimension of the board. Please allow enough space between the SMA connectors for proper connection with test cables.
- The frequency bands are defined as:

Band	TX band / MHz	RX band / MHz
1	1,920 – 1,980	2,110 – 2,170
2	1,850 – 1,910	1,930 – 1,990
3	1,710 – 1,785	1,805 – 1,880
7	2,500 – 2,570	2,620 – 2,690

- All measurements are referenced to 50Ω impedance.
- We provide a standard DC power supply with 0 to 100 V DC for powering the RF-MEMS components. The connection will be 4mm banana plugs.
- The board must contain at least proper DC switches to select the band of interest. The implementation of a microcontroller with switching logic is optional.

Evaluation Process:

The designs will be evaluated by a commission at IMS 2024 based on measurements taken on site. For the evaluation, only small signal parameters and the board design will be considered. In case of equal or very close results, the jury may consider additional criteria such as practicability and workmanship.

The performance will be evaluated based on six different states:

State	Antenna Switch	TX-Switch
I	Bands 1/3/7, carrier aggregated	Band 1
II	Bands 1/3/7, carrier aggregated	Band 3
III	Bands 1/3/7, carrier aggregated	Band 7
IV	Band 2	Band 2
V	Bands 2/7, carrier aggregated	Band 2
VI	Bands 2/7, carrier aggregated	Band 7

The figure of merit (in logarithmic domain) is defined as follows:

$$\text{FoM} = \sum_{\forall \text{ States}} |s_{21}| + |s_{31}| - (VSWR_{11} + VSWR_{22} + VSWR_{33})$$

The s-parameter measurements will be taken at room temperature and -10 dBm power level at all ports. The values are the minimum/maximum values in all (carrier aggregated) bands assigned to the state/ports. The values will be rounded towards lower performance to the first decimal, e.g., $|s_{21}| = -1.53\text{dB} \Rightarrow -1.6\text{dB}$ and $|s_{11}| = -10.53\text{dB} \Rightarrow -10.5\text{dB}$.

The board size must be $5 \times 5 \text{ cm}^2$ at least. Boards, smaller in one or both dimensions, will be disqualified.

The device will be considered in case that,

- all transmission parameters ($|s_{21}|$, $|s_{31}|$) $\geq -5 \text{ dB}$ across the bands,
- matching at all ports ($|s_{11}|$, $|s_{22}|$, $|s_{33}|$) $\leq -6 \text{ dB}$ across the individual bands.

In case one of the previous criteria is not met by the circuit presented at IMS 2024 the circuit is not qualified for the contest.

How to Participate:

Competing teams will be required to register to the IMS Student Design Competition according to the rules posted on the IMS-2024 homepage.

In addition, participants must meet the following eligibility requirements:

- Students may enter as individuals or as a team. There may be no more than four students on a team. Each student may be a member of only one team. Each team may submit up to two entries but can receive an award for only one entry.
- To enter a competition, the student(s) must have been full-time student(s) (enrolled for a minimum of nine hours per term as graduate students or twelve hours per term as undergraduates) during the time the work was performed. There is no restriction on age.
- The student(s) must have a signed statement from their academic advisor that the work is principally the effort of the student(s).
- At least one of the students on a team must register for and attend the conference to demonstrate their design for evaluation during the contest day at IMS 2024.
- The student(s) must submit an entry form to the Student Design Competition co-chairs, who will also provide the form. Please send a copy of the form also to mtt2sdc@listserv.ieee.org to receive the components.
- The students should use the email address issued by their respective institutions for all communication regarding the competitions, rather than their personal emails (e.g., Gmail, Hotmail).

Prizes:

There will be two prizes awarded. The first and second place winner will receive \$1,500 and \$500, respectively. The winner is invited to submit a paper describing the design in the MTT's Microwave Magazine.

Contact Information:

- Thomas Forster: Thomas.forster@ieee.org
- Andreas Tag: andreas.tag@qorvo.com
- Andreas Link: andreas.link@qorvo.com
- Chris Giovanniello: chris.giovanniello@menlomicro.com